

▽ (▽▽) <sup>G</sup>

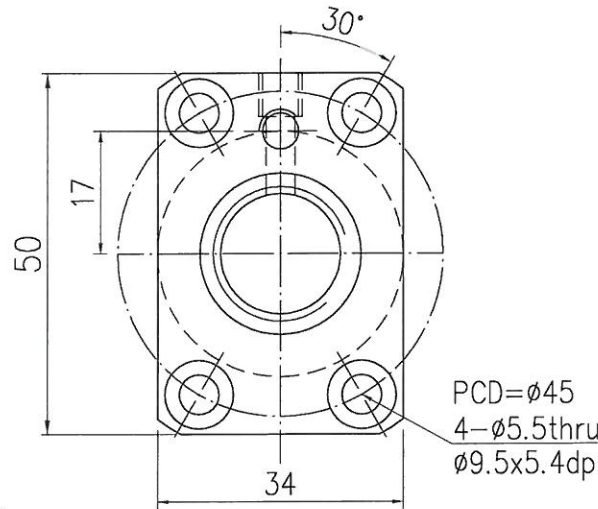
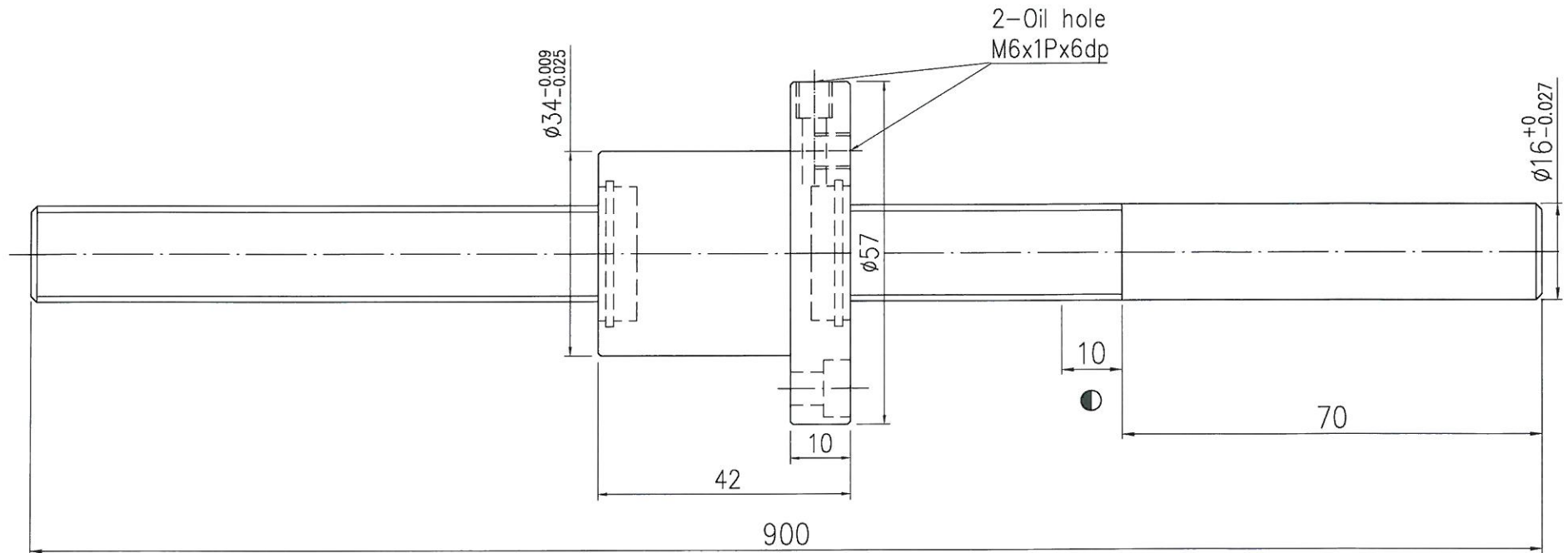

BASIC RATED DYNAMIC LOAD (kgf)	1049
BASIC RATED STATIC LOAD(kgf)	1144
THREAD DIR. /NO. OF START THD	RIGHT/ 1
BCD (mm)	φ16.545
LEAD (mm)	5
BALL DIA.(mm)	φ3.175
ROOT DIA.	φ19.72
EFFECTIVE TURNS (CIRCUITxROW)	1X3
LEAD ANGLE	5.5°

Ball Nut Dwg NO PFAR1605T3DV00

TOLERANCES FOR REGULAR DIMENSIONS (MM)				SURFACE ROUGHNESS Ra(μm)
RANGE	TOLERANCE	RANGE	TOLERANCE	
0.5-6	±0.1	401-1000	±0.8	▽ FINE FINISH 6.3a
7-30	±0.2	1001-2000	±1.2	
31-120	±0.3	2001-4000	±2.0	G GRIND FINISH 1.6a
121-400	±0.5	4001 OVER	±3.0	

CUSTOMER: POWER

SPEC=R16-05T3-1-PFAD-830-900-0.05-W-P1

(註: 未標之倒角皆為C0.5) ● NOT EFFECTIVE HARDENED AREA (不在有效熱處理範圍內)  
 Note: Chamferings are C0.5 if not specified otherwise

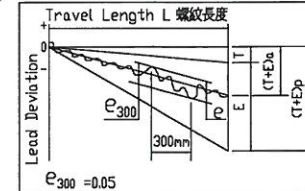

AXIAL PLAY		
DRAG	CENTER	0
TORQUE (kgf-cm)	RANGE	0
	SPRING FORCE (kgf)	0
THREAD PROFILE		
GOTHIC		

Accessory	QTY	Accessory	QTY
循環器	3		
刮刷器	2		
六角彈簧	2		

DRAW	張家豪
CHECK	翁豐藝
APPROVE	田力
DATE	102-06-13

**GTEN**  
 GTEN BALL SCREW TECHNOLOGY

DWG NO. 13A2405  
 CUSTOMER'S DWG. NO. ISSOKU

SCALE 1: X

MATERIAL 材質	SCREW ROLLED S55C_Ground 50CrMo4
	NUT SCM415H
HARDNESS 熱處理	SCREW 滾珠牙部 HRC58°-62°
	NUT 滾珠牙部 HRC58°-62°