



ARC/HRC/ERC series

Linear motion technology

ARC/HRC/ERC Ball Type Linear Guide Series

Product Overview

ARC/HRC/ERC Product Characteristics

The **cpc** ARC/HRC/ERC Linear Guide Series uses the O-type arrangement for the four row ball circulation design. The contact angle between the rail and ball is 45 degrees, and can realize the 4 directional load effects. **cpc** places special emphasis on strengthening the Arm length(L_o), so when sustaining external force F , will have even higher M_r value to increase the rigidity and static moment capability. In addition, the runner block for the same size uses larger and more balls, so will outperform competitor's models by 10% to 30% regarding load capabilities. The products have characteristics of high load, high moment, and high stiffness.

Unit:mm

Mode Code	L_o	H_c
15	12.4	9.35
20	16.4	12.5
25	19.5	14.5
30	24.0	17
35	30.4	19.5
45	38.2	24
55	43.1	28.5

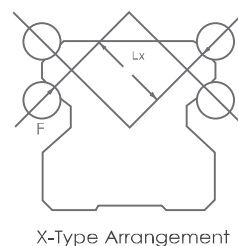
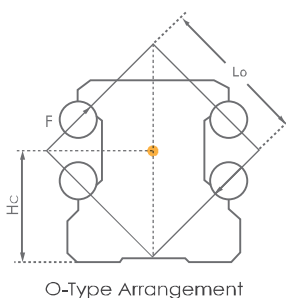

$$F = M_r / L_o (L_x)$$

Stainless steel reinforcement plate

- Total scraping of objects above 0.3mm
- Increase X-axis direction force capacity

LINEAR MOTION TECHNOLOGY

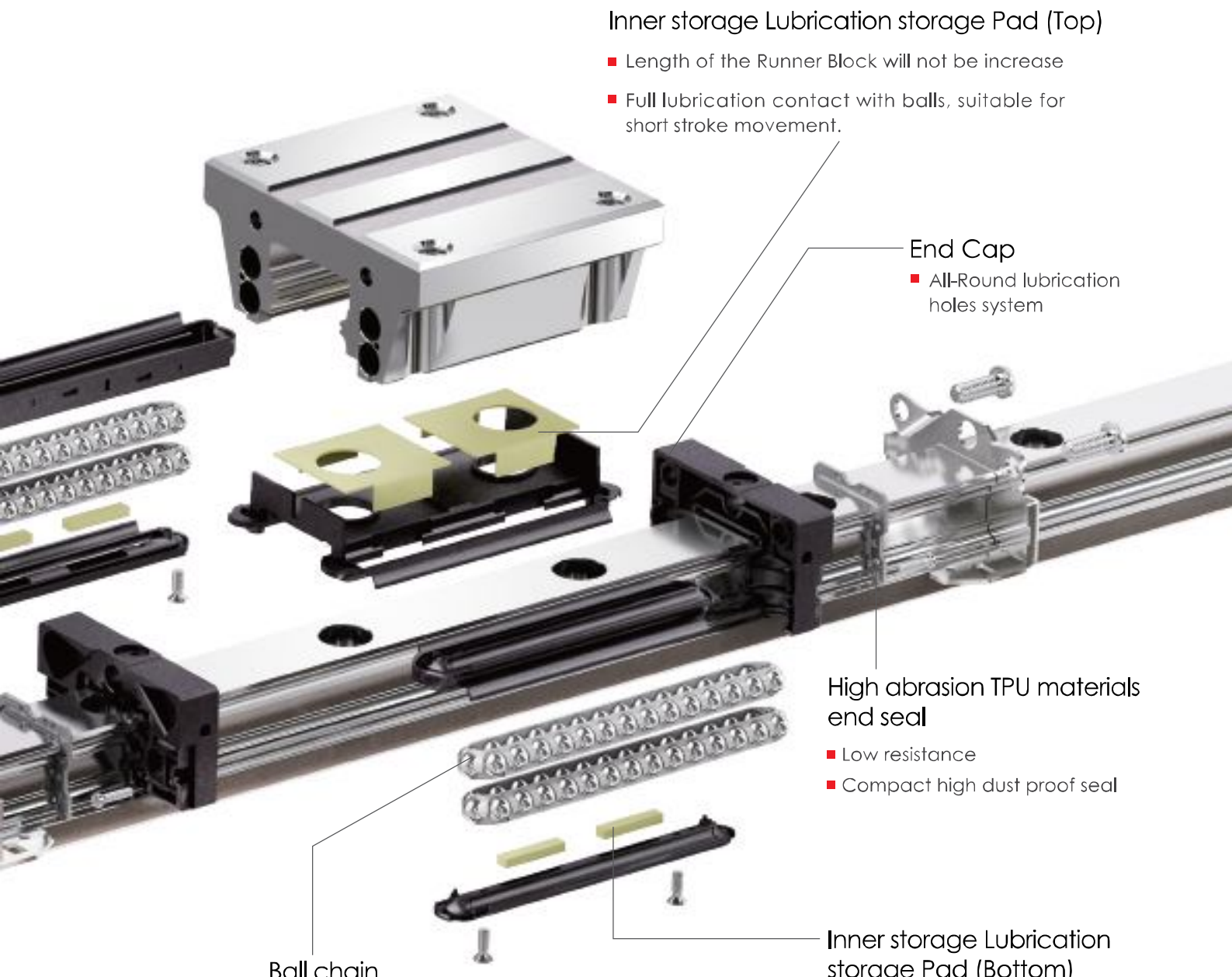

Inner storage Lubrication storage Pad (Top)

- Length of the Runner Block will not be increase
- Full lubrication contact with balls, suitable for short stroke movement.

End Cap

- All-Round lubrication holes system

High abrasion TPU materials end seal

- Low resistance
- Compact high dust proof seal

Ball chain

- Patented design of reverse operations
- Quiet and prolong the service life

Inner storage Lubrication storage Pad (Bottom)

- High Dynamic Load and High Load capabilities
- Excellent dynamic performance: $V_{max} > 10 \text{ m/s}$ $a_{max} > 500 \text{ m/s}^2$
- Can provide tapped from the top and tapped from the bottom rail
- Can provide special surface treatment

Product Design

Ball Chain Patent Design

Traditional Ball type linear guide, producing double the speed of slide contact with neighboring balls in different directions for spinning effects. Extremely high friction greatly reduce service life; also, the contact point between balls produce high pressure and noise, and increase the possibility of damagers of film cladding.

Ball chain can provide greater contact area between ball and ball chain, so film cladding will eliminate damage and lower noise level. Balls can move at higher speed and prolong service life.



Rotational ball chain

- Reduce noises
- Higher speed in motion
- Prolong Service Life
- Prolong re-lubrication period

The **cpc** uniquely patented ball chain design provide a flexible link between the blocks and between balls, giving the ball chain enough space to rotate and move in the circulation channel and overcome the friction of the curvature. In addition, the space between upper and bottom part have oil storage functions, increasing the re-lubrication interval and service life

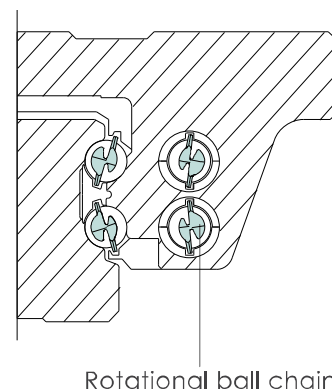
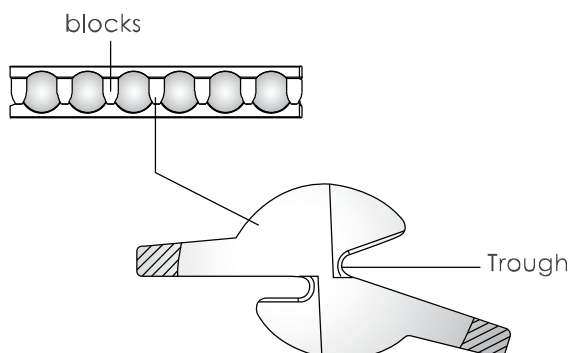

Lubrication Design

Inner oil storage and oil supply system design

Inner PU Lubrication Storage Pad design does not increase length of runner block and can contact directly with all balls. Customer can inject lubrication oil through lubrication holes and can save enough lubrication oil within the PU Lubrication storage pad to ensure long term lubrication effects, conforming to environment protection needs and lowering maintenance costs. Excellent performance when used in short stroke.

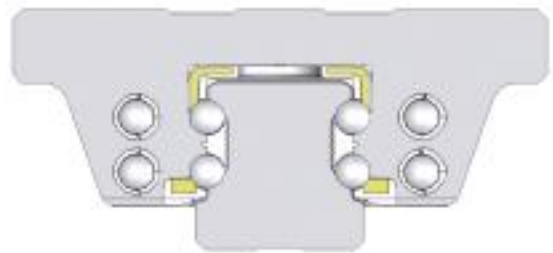

Upper Lubrication Storage Pad

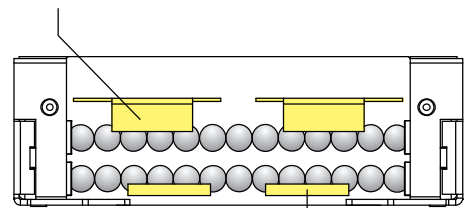

Bottom Lubrication Storage Pad

All-direction Lubrication Nozzles

On the top, bottom, and sides, there are oil injection nozzles designed, the upper runner block comes with O-ring seal, and easily complete the oiling from top. Diversified comprehensive oil injection methods, suitable for installation axial and oil injection methods.

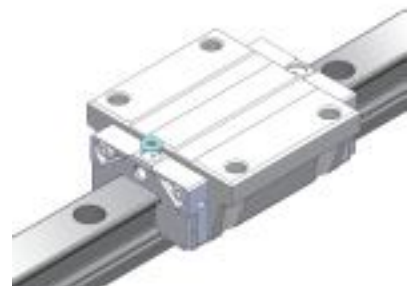
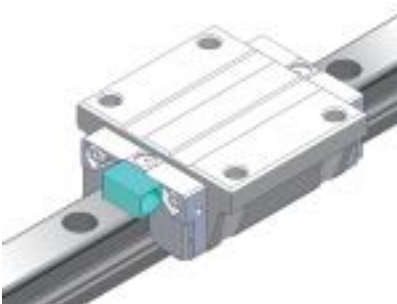

Product Design

Dustproof design

Stainless Steel Reinforcement Plate

With clearance between rail profile of no more than 0.3mm, the plate can scrape large items such as iron filings to protect the end seals

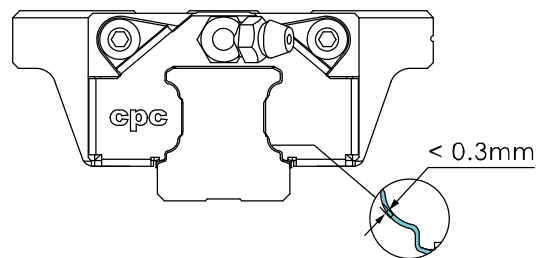

Inner seals

The newly designed inner seals, can protect foreign objects from sliding into the rails while maintaining low friction. It can also allow the lubrication oil to be maintained inside the runner block and prolong the re-lubricatio interval.

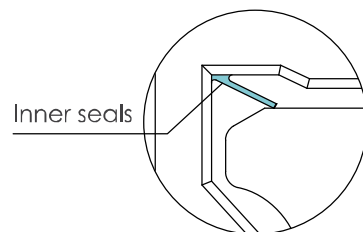

Bottom Seals

The bottom seals can prevent foreign objects from entering the bottom and prevent lubrication from leaking out. With full sealing design, it reduces the amount of oil usage, prolong the re-lubrication interval, and prolong the service life.

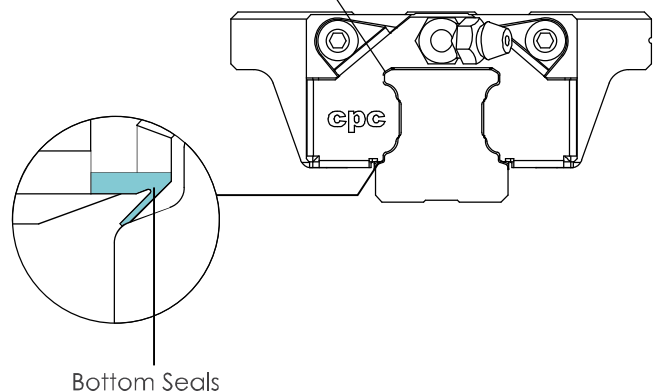

End Seals

The **cpc** double lips type end seals can prevent foreign objects from entering from the side and preventing lubrication oil and grease from leaking. The flexibility of the engineering plastic material TPU has better friction resistance ability and better prevents cracking characteristics than typical NBR plastic.

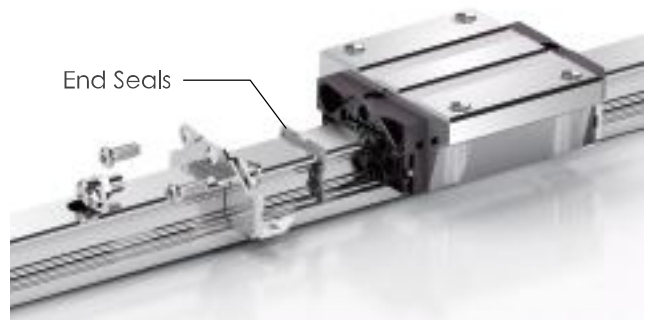

Standard seals (B)

Suitable for most conditions, with slight contact with the rail, and having both scraping function with low friction.

Reinforcement seals (S)

Directly in contact with the rail surface, having better dustproof and lubrication holding capabilities. **cpc** recommends using this type of seals in environments that is exposed for long durations to high dusts and Saw wood dust, etc. The friction will be higher than standard seals

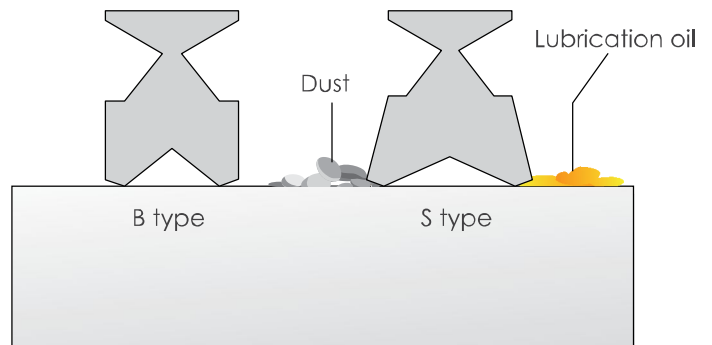

Comparison of friction of seals

The friction will be highest on new linear rails. After short period of operation, friction will reduce to a constant level.

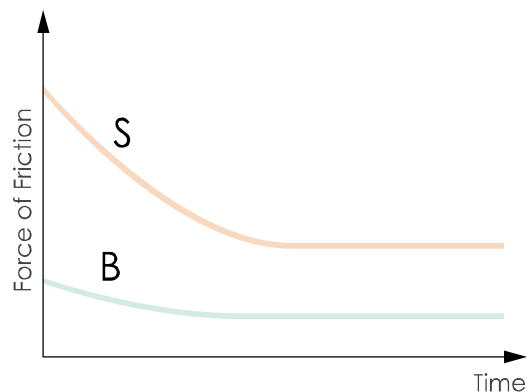

Product Design

Saw wood dust Test

Test content

This test uses a total of 4 groups of products (using 2 rails match with 2 lubrications methods) by putting in saw wood dust and moving them within.

Rail

1. Tapped from top rail plus hole plugs (AR)
2. Tapped from bottom rail (ARU)

Runner Block

1. Installation of reinforcement seals (S), using grease
2. Installation of lubrication storage Pad and reinforcement seals (SZ), using grease

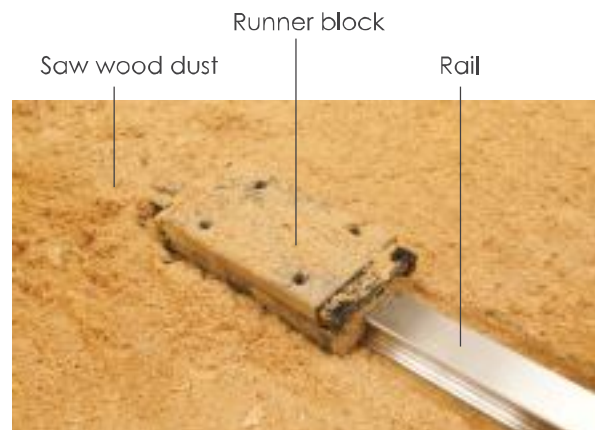

Testing conditions

1. Stroke = 600mm
2. Total testing stroke = 30m

Test items

1. If Saw wood dust enters the inner parts of the runner block
2. If Saw wood dust enters the ball raceway

Test results



Tapped from bottom (oil) Tapped from bottom (grease)

Checked Item	Saw wood dust enter inner part of runner block	Saw wood dust enter ball bearing runner area
Installation status		
ARU Rail SZ Type Runner Block (Grease oil)	No	No
ARU Rail S Type Runner Block (Grease lubrication)	No	No
AR Rail SZ Type Runner Block (Grease Oil)	Yes (belly area)	No
AR Rail S Type Runner Block (Grease Lubrication)	Yes (belly area)	No

Test result

- The Tapped from top rail has hole plugs, leading to unevenness of rail, allowing some saw wood dust to enter the runner block belly area. The 2 sides of the runner block belly area is protected by stainless steel reinforcement plates and end seals that completely protect the ball bearing, so the ball bearing runner area is fully protected from Saw wood dust.
- The tapped from bottom rail has even rail surface, so the ball bearing runner area is fully protected from Saw wood dust.

Product Design

Reinforcement plate patent design

Using 2 stainless steel reinforcement plates, the L type design can fasten the screws onto the top and bottom of the runner block, reinforcing the rigidity of the end caps and cladding.

The clearance between the rail profile with the seal design is below 0.3mm, reinforcing the steel plates while having scraper functions.

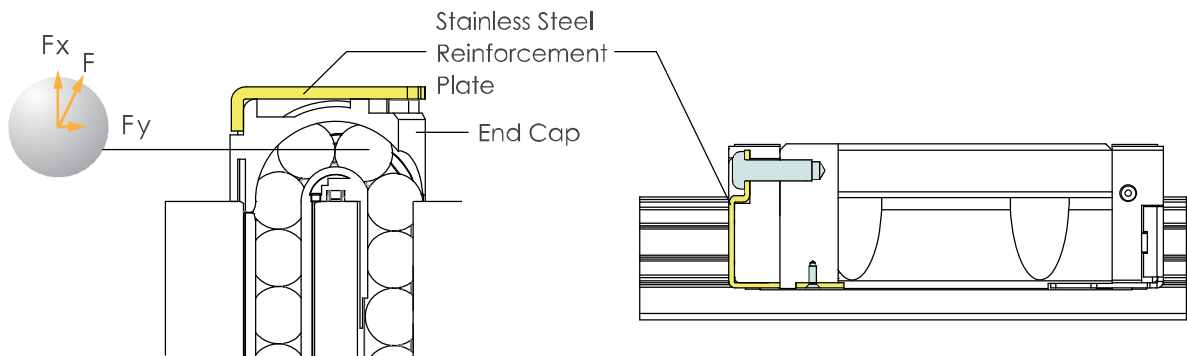

The ARC/HRC/ERC type uses the stainless steel reinforcement plates to strengthen the bottom latches, while increasing X-axis direction force capacity, and increasing operation speed.

$V_{max} > 10 \text{ m/s}$ $a_{max} > 500 \text{ m/s}^2$

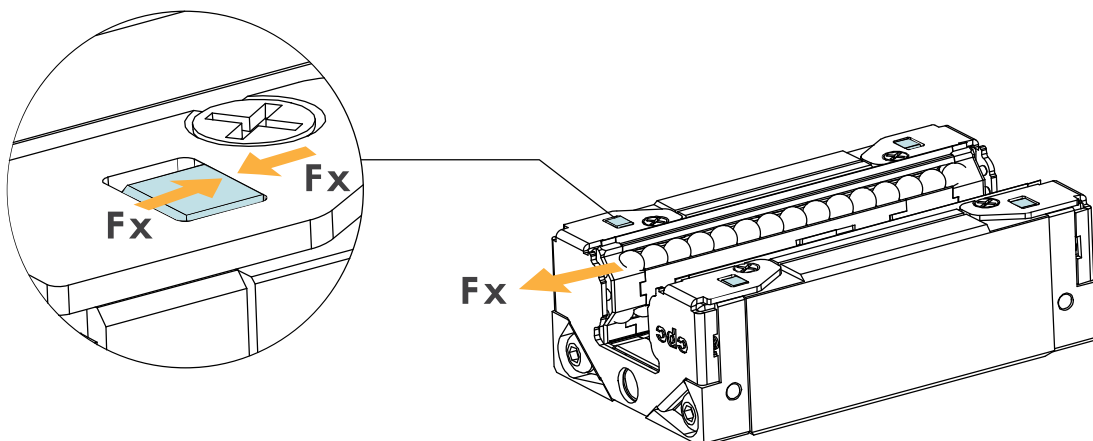

Installation Notice

Dimension of reference edge

To ensure the linear guide is precisely assembled with machine table, **cpc** machines a recess in the reference edge corner. The corner of the machine table must be smaller than the chamfer of the linear guide to avoid interference.

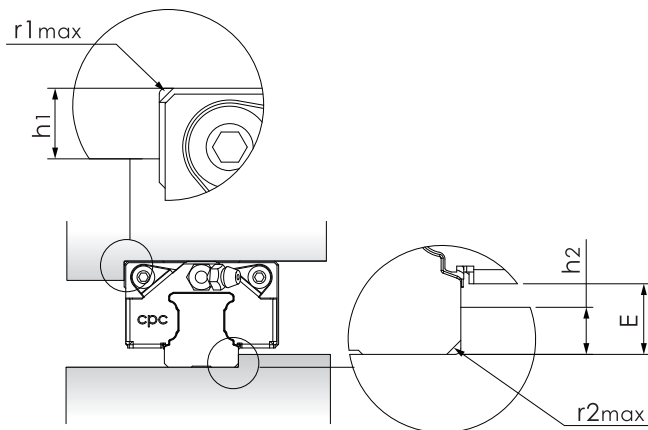

Unit : mm

Type	r1max	r2max	h1	h2	E
15	0.5	0.5	4.0	2.5	3.3
20	0.5	0.5	5.0	4.0	5.0
25	1.0	1.0	5.0	5.0	6.0
30	1.0	1.0	6.0	5.5	6.6
35	1.0	1.0	6.0	6.5	7.6
45	1.0	1.0	8.0	8.0	9.3
55	1.5	1.5	10.0	10.0	12.0

Rail Joint

The standard length of rail is 4 meter, **cpc** provides rail joint solution. The joint number will be laser mark on the rail.

1. Follow the joint number to assemble. (Shown in figure A)
2. In the case of two more numbers of rail on the same moving axis, **cpc** suggests to set the joint in different position to avoid the change in accuracy. (Shown in figure B)
3. Follow the recommend tightening torques to fasten the screws from inside to outside.

Figure A



Figure B

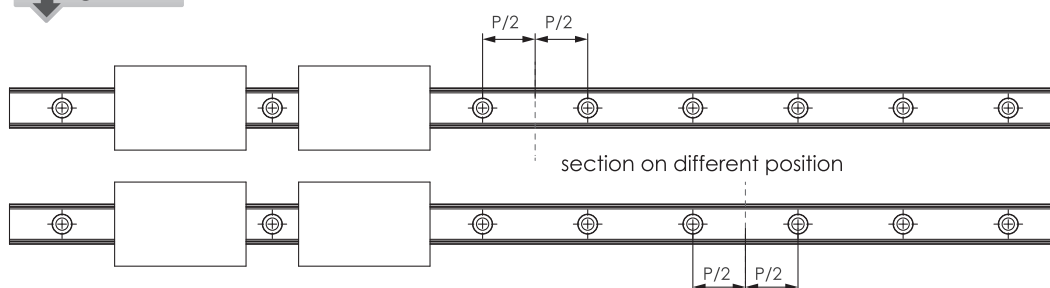

Technical information

Preload and clearance

The ARC/HRC/ERC linear guides provide 4 different preload class VC, V0, V1, V2.

ARC										
Class	Description	Preload Value	Clearance (µm)							Application
			15	20	25	30	35	45	55	
VC	Micro gap	0	+10~+2	+10~+2	+11~+3	+12~+4	+12~+4	+13~+5	+13~+5	Smooth motion, low friction
V0	Light preload	0.02C	+2~-4	+2~-5	+3~-6	+4~-7	+4~-8	+5~-10	+5~-12	For precision situations, smooth motion
V1	Medium Preload	0.05C	-4~-10	-5~-12	-6~-15	-7~-18	-8~-20	-10~-24	-12~-28	High stiffness, precision, high load situations
V2	Heavy Preload	0.08C	-10~-16	-12~-18	-15~-23	-18~-27	-20~-31	-24~-36	-28~-45	Super High stiffness, precision, super high load situations

HRC/ERC										
Class	Description	Preload Value	Clearance (µm)							Application
			15	20	25	30	35	45	55	
VC	Micro gap	0	+10~+2	+10~+2	+11~+3	+12~+4	+12~+4	+13~+5	+13~+5	Smooth motion, low friction
V0	Light preload	0.02C	+2~-4	+2~-5	+3~-6	+4~-7	+4~-8	+5~-10	+5~-12	For precision situations, smooth motion
V1	Medium Preload	0.08C	-4~-12	-5~-14	-6~-16	-7~-19	-8~-22	-10~-25	-12~-29	High stiffness, precision, high load situations
V2	Heavy Preload	0.13C	-11~-19	-14~-23	-16~-26	-19~-31	-22~-35	-25~-40	-29~-46	Super High stiffness, precision, super high load situations

Technical information

Accuracy

The ARC/HRC/ERC linear guides provide 5 different classes of precision : N, H, P, SP, and UP class, Engineers can choose different class depend on the machine applications.

Accuracy

	Table of accuracy					
	Accuracy grades (μm)		UP	SP	P	H
Tolerance of demension height H	H	±5	±10	±20	±40	±100
Variation of height for different runner Block on the same position of Rail	ΔH	3	5	7	15	30
Tolerance of demension width W ₂	W ₂	±5	±7	±10	±20	±40
Variation of width for different runner Block on the same position of Rail	ΔW_2	3	5	7	15	30

Accuracy of the running parallelism

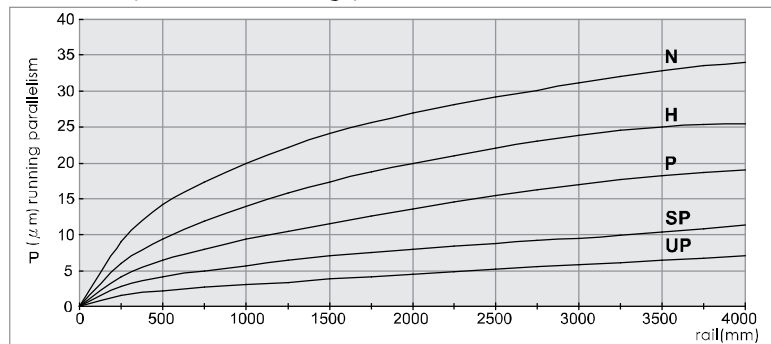

Application

class	Movement, Motion	Manufacturing Equipment	High Precision manufacturing equipment	Test Equipment
N	●	●		
H	●	●	●	
P		●	●	●
SP			●	●
UP				●
Examples	Mechanical Movers Industrial robots Office Machinery	Woodworking machine Punching press injection Molding machine	1.Lathe/milling machine/ grinding machine 2.electrical discharge machining (EDM) 3. CNC machining center	Three dimensional measuring instrument Detection mirror/ head shaft XY Platform

Ordering information

Model code																
ARC	U	15	M	N	B	2	Z	C	V1	P	-1480L	-20	-20	II	J	
Customization code																
Number of rails on the same moving axis																
End hole pitch (mm)																
Starting hole pitch (mm)																
Rail length (mm)																
Accuracy class : UP, SP, P, H, N																
Preload class : VC, V0, V1, V2																
C: with ball chain																
Z: with lubrication storage pad																
Block quantity																
Seal type : B: standard S: reinforcement																
Block length : L: long N: standard S: short																
Block width : M: standard F: flanged																
Block type : 15, 20, 25, 30, 35, 45, 55																
U: rail (tapped from the bottom)																
Product type : ARC: automation series HRC/ERC: heavy load series																

Customized needs (The meaning of the suffix letter Description)

J : Butt-jointing track rail

G : Customer designate lubricant

I : Attached inspection report

N: Entire unit's surface plated nickel

NR: Only rail surface plated nickel

R: Entire unit's surface Raydent plated

RR: Only rail surface Raydent plated

C : Chrome surface treatment is applied to the casing and track rail

Cr : Chrome surface treatment is applied to the track rail

B: Entire unit's surface coated with black chrome

BR: Only rail surface treated with black chrome

Note: If there is any customize need, please contact **cpc** for more information.

Dimensions Table

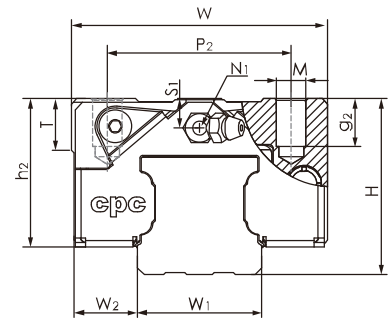

ARC MS Series

Model Code	Mounting Dimensions		Rail Dimensions(mm)				Block Dimensions(mm)									
	H	W ₂	W ₁	H ₁	P	Dx dx ₁ xg ₁	W	L	L ₁	h ₂	P ₁	P ₂	M x G ₂	M ₁	T	N ₁
ARC 15 MS	24	9.5	15	15	60	7.5x4.5x5.3	34	40.4	26	20.7	-	26	M4x7	-	6	M3x6.5
ARC 20 MS	28	11	20	20	60	9.5x6x8.5	42	49.2	32.2	23	-	32	M5x7	-	8	M3x7.5
ARC 25 MS	33	12.5	23	23	60	11x7x9	48	57.4	38.4	27	-	35	M6x9	-	8	M6x7.5
ARC 30 MS	42	16	28	27	80	14x9x12	60	68	44	35.2	-	40	M8x10	-	12	M6x8.5

ARC MN Series

ARC 15 MN	24	9.5	15	15	60	7.5x4.5x5.3	34	55.5	40.3	20.7	26	26	M4x7	-	6	M3x6.5
ARC 20 MN	28	11	20	20	60	9.5x6x8.5	42	69	52	23	32	32	M5x7	-	8	M3x7.5
ARC 25 MN	33	12.5	23	23	60	11x7x9	48	81.2	62.2	27	35	35	M6x9	-	8	M6x7.5
ARC 30 MN	42	16	28	27	80	14x9x12	60	95.5	71.5	35.2	40	40	M8x10	-	12	M6x8.5
ARC 35 MN	48	18	34	32	80	14x9x12	70	111.2	86.2	40.4	50	50	M8x13	-	14	M6x10
ARC 45 MN	60	20.5	45	39	105	20x14x17	86	135.5	102.5	50.7	60	60	M10x20	-	14	PT1/8x12.5
* ARC 55 MN	70	23.5	53	46	120	20x16x18	100	155.6	118.6	58	75	75	M12x20	-	16	PT1/8x14.5

ARC ML Series

ARC 30 ML	42	16	28	27	80	14x9x12	60	118	94	35.2	60	40	M8x10	-	12	M6x8.5
ARC 35 ML	48	18	34	32	80	14x9x12	70	136.6	111.6	40.4	72	50	M8x13	-	14	M6x10
ARC 45 ML	60	20.5	45	39	105	20x14x17	86	171.5	138.5	50.7	80	60	M10x20	-	14	PT1/8x12.5

1. The model is in design

3. N₂ = Injecting holes

5. N₂ will be seal before shipment, open it when using product.

2. The load capacities is for-full ball type (No ball chain)

4. N₃ = O-ring seal

LINEAR MOTION TECHNOLOGY

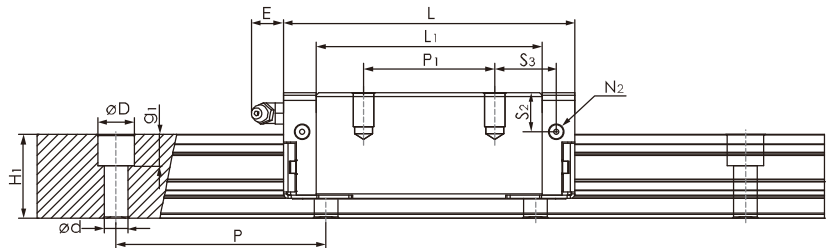
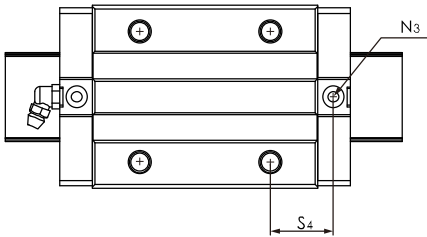

Block Dimensions(mm)							Load Capacities (KN)		Static Moment (Nm)			Weight		Model Code
N ₂	N ₃	E	S ₁	S ₂	S ₃	S ₄	C	C ₀	M _{r0}	M _{p0}	M _{y0}	Block(g)	Rail(g/m)	
M3x6	P3	3.5	4.5	7.5	15.7	16.8	7.7	9.8	100	50	50	96	1290	ARC 15 MS
M3x5.5	P4	10	4	7.4	19.1	19.8	12.5	15.5	205	100	100	170	2280	ARC 20 MS
M3x6.5	P4	12	5	9.3	22.2	23.2	18.2	22.0	350	160	160	300	3020	ARC 25 MS
M6x5	P5	12	7.5	12	27	26.7	23.3	26.7	435	230	230	560	4380	ARC 30 MS

M3x6	P3	3.5	4.5	7.5	9.8	10.9	9.9	14.1	140	105	105	142	1290	ARC 15 MN
M3x5.5	P4	10	4	7.4	13	13.7	17.1	24.2	325	230	230	266	2280	ARC 20 MN
M3x6.5	P4	12	5	9.3	16.6	17.6	24.8	34.3	540	385	385	420	3020	ARC 25 MN
M6x5	P5	12	7.5	12	20.8	20.5	32.8	43.3	705	565	565	800	4380	ARC 30 MN
M6x7	P5	12	8	15	23.4	24.1	45.9	60.9	1505	955	955	1120	6790	ARC 35 MN
M6x10.5	P5	14	11.1	18.1	27.3	27.2	71.3	89.8	2780	1660	1660	2120	10530	ARC 45 MN
M6x12.5	P5	14	12	19.5	28.5	29.5	103.4	127.3	3945	2725	2725	3880	14060	ARC 55 MN

M6x5	P5	12	8.7	12	21.7	21.7	39.6	56.6	960	960	960	1138	4380	ARC 30 ML
M6x7	P5	12	8	15	25.1	25.8	54.7	78.3	1935	1935	1935	1536	6790	ARC 35 ML
M6x10.5	P5	14	11.1	18.1	35	35	89.5	124.4	3850	3060	3060	3160	10530	ARC 45 ML

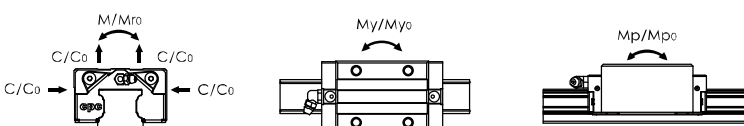

The above rating load capacities and static moment are calculated according to ISO14728 standard. The rating life for basic dynamic load rating is defined as the total 100km travel distance that 90% of a group of identical linear guides can be operated individually under the same conditions free from any material damage caused by rolling fatigue. When the standard of 50km travel distance is applied, the above basic dynamic load rating C of ISO 14728 should be multiplied by 1.26 for conversion.

Dimensions Table

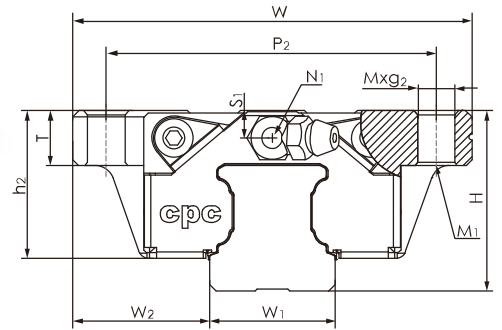

ARC FS Series

Model Code	Mounting Dimensions		Rail Dimensions(mm)				Block Dimensions(mm)									
	H	W ₂	W ₁	H ₁	P	D _x d _x g ₁	W	L	L ₁	h ₂	P ₁	P ₂	M _x G ₂	M ₁	T	N ₁
ARC 15 FS	24	18.5	15	15	60	7.5x4.5x5.3	52	41.2	26	20.7	-	41	M5x7	M4	7	M3x6.5
ARC 20 FS	28	19.5	20	20	60	9.5x6x8.5	59	49.2	32.2	23	-	49	M6x10	M5	10	M3x7.5
ARC 25 FS	33	25	23	23	60	11x7x9	73	57.4	38.4	27	-	60	M8x12	M6	12	M6x7.5
* ARC 30 FS	42	31	28	27	80	14x9x12	90	68	44	35.2	-	72	M10x15	M8	15	M6x8.5

ARC FN Series

ARC 15 FN	24	18.5	15	15	60	7.5x4.5x5.3	52	55.5	40.3	20.7	26	41	M5x7	M4	7	M3x6.5
ARC 20 FN	28	19.5	20	20	60	9.5x6x8.5	59	69	52	23	32	49	M6x10	M5	10	M3x7.5
ARC 25 FN	33	25	23	23	60	11x7x9	73	81.2	62.2	27	35	60	M8x12	M6	12	M6x7.5
ARC 30 FN	42	31	28	27	80	14x9x12	90	95.5	71.5	35.2	40	72	M10x15	M8	15	M6x8.5
ARC 35 FN	48	33	34	32	80	14x9x12	100	111.2	86.2	40.4	50	82	M10x15	M8	15	M6x10

1. The model is in design

3. N₂ = Injecting holes

5. N₂ will be seal before shipment, open it when using product.

2. The load capacities is for-full ball type (No ball chain)

4. N₃ = O-ring seal

LINEAR MOTION TECHNOLOGY

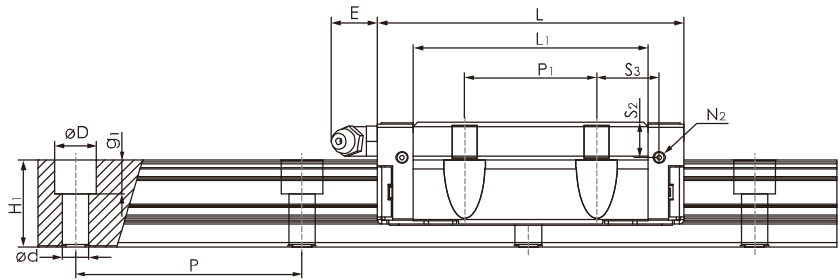
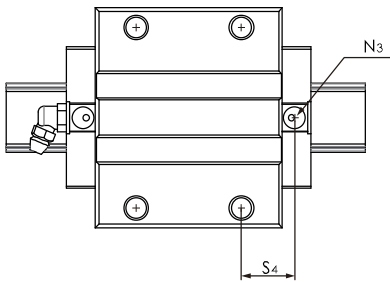

Block Dimensions(mm)							Load Capacities (kN)		Static Moment (Nm)			Weight		Model Code
N_2	N_3	E	S_1	S_2	S_3	S_4	C	C_0	M_{r0}	M_{p0}	M_{y0}	Block(g)	Rail(g/m)	
M3x6	P3	3.5	4.5	7.5	15.7	16.8	7.7	9.8	100	50	50	122	1290	ARC 15 FS
M3x5.5	P4	10	4	7.4	19.1	19.8	12.5	15.5	205	100	100	210	2280	ARC 20 FS
M3x6.5	P4	12	5	9.3	22.2	23.2	18.2	22.0	350	160	160	345	3020	ARC 25 FS
M6x5	P5	12	7.5	12	27	26.8	23.3	26.7	435	230	230	750	4380	ARC 30 FS

M3x6	P3	3.5	4.5	7.5	8.9	10.9	9.9	14.1	140	105	105	184	1290	ARC 15 FN
M3x5.5	P4	10	4	7.4	13	13.7	17.1	24.2	325	230	230	336	2280	ARC 20 FN
M3x6.5	P4	12	5	9.3	16.6	17.6	24.8	34.3	540	385	385	524	3020	ARC 25 FN
M6x5	P5	12	7.5	12	20.8	20.5	32.8	43.3	705	565	565	1200	4380	ARC 30 FN
M6x7	P5	12	8	15	23.4	24.1	45.9	60.9	1505	955	955	1580	6790	ARC 35 FN

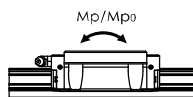
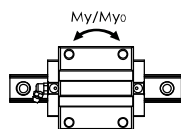
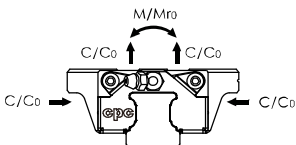

The above rating load capacities and static moment are calculated according to ISO14728 standard. The rating life for basic dynamic load rating is defined as the total 100km travel distance that 90% of a group of identical linear guides can be operated individually under the same conditions free from any material damage caused by rolling fatigue. When the standard of 50km travel distance is applied, the above basic dynamic load rating C of ISO 14728 should be multiplied by 1.26 for conversion.

Dimensions Table

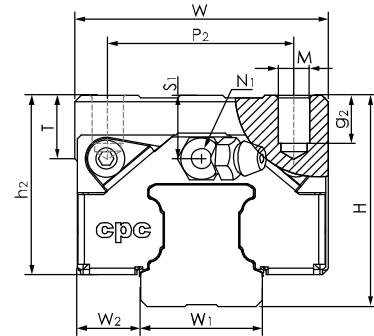

HRC MN Series

Model Code	Mounting Dimensions		Rail Dimensions(mm)				Block Dimensions(mm)									
	H	W ₂	W ₁	H ₁	P	Dxdxg ₁	W	L	L ₁	h ₂	P ₁	P ₂	Mxg ₂	M ₁	T	N ₁
HRC 15 MN	28	9.5	15	15	60	7.5x4.5x5.3	34	55.5	40.3	24.7	26	26	M4x7	-	6	M3x6.5
HRC 20 MN	30	12	20	20	60	9.5x6x8.5	44	69	52	25	36	32	M5x8.5	-	8	M3x7.5
HRC 25 MN	40	12.5	23	23	60	11x7x9	48	81.2	62.2	34	35	35	M6x9	-	12	M6x7.5
HRC 30 MN	45	16	28	27	80	14x9x12	60	95.5	71.5	38.4	40	40	M8x12	-	12	M6x8.5
HRC 35 MN	55	18	34	32	80	14x9x12	70	111.2	86.2	47.4	50	50	M8x13	-	14	M6x10
HRC 45 MN	70	20.5	45	39	105	20x14x17	86	135.5	102.5	60.7	60	60	M10x20	-	14	PT1/8x12.5
* HRC 55 MN	80	23.5	53	46	120	24x16x18	100	155.6	118.6	68	75	75	M12x24	-	16	PT1/8x14.5

HRC ML Series

HRC 20 ML	30	12	20	20	60	9.5x6x8.5	44	87.2	70.2	25	50	32	M5x8.5	-	8	M3x7.5
HRC 25 ML	40	12.5	23	23	60	11x7x9	48	105	86	34	50	35	M6x9	-	12	M6x7.5
HRC 30 ML	45	16	28	27	80	14x9x12	60	118	94	38.4	60	40	M8x12	-	12	M6x8.5
HRC 35 ML	55	18	34	32	80	14x9x12	70	136.6	111.6	47.4	72	50	M8x13	-	14	M6x10
HRC 45 ML	70	20.5	45	39	105	20x14x17	86	171.5	138.5	60.7	80	60	M10x20	-	14	PT1/8x12.5
* HRC 55 ML	80	23.5	53	46	120	24x16x18	100	202.5	165.5	68	95	75	M12x24	-	16	PT1/8x14.5

ERC Series

ERC 25 MN	36	12.5	23	23	60	11x7x9	48	81.2	62.2	30	35	35	M6x9	-	8	M6x7.5
ERC 25 ML	36	12.5	23	23	60	11x7x9	48	105	86	30	50	35	M6x9	-	8	M6x7.5

1. The model is in design

3. N₂ = Injecting holes

5. N₂ will be seal before shipment, open it when using product.

2. The load capacities is for-full ball type (No ball chain)

4. N₃ = O-ring seal

LINEAR MOTION TECHNOLOGY

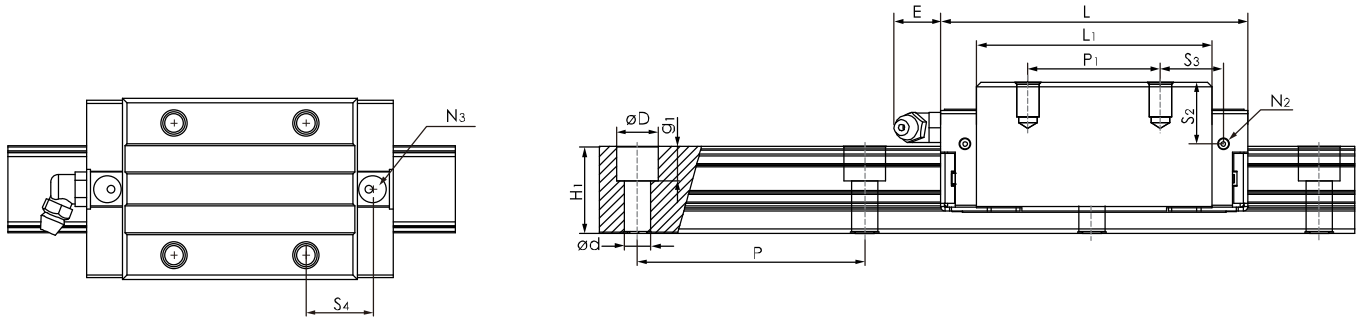

Block Dimensions(mm)							Load Capacities (KN)		Static Moment (Nm)			Weight		Model Code
N2	N3	E	S1	S2	S3	S4	C	C0	Mr0	Mp0	My0	Block(g)	Rail(g/m)	
M3x6	P3	3.5	8.5	11.5	9.8	10.9	9.9	14.1	140	105	105	184	1290	HRC 15 MN
M3x5.5	P4	10	6	9.4	11	11.7	17.1	24.2	325	230	230	318	2280	HRC 20 MN
M3x6.5	P4	12	12	16.3	16.6	17.6	24.8	34.3	540	385	385	578	3020	HRC 25 MN
M6x5	P5	12	10.5	15	20.8	20.5	32.8	43.3	705	565	565	896	4380	HRC 30 MN
M6x7	P5	12	15	22	23.4	24.1	45.9	60.9	1505	955	955	1430	6790	HRC 35 MN
M6x10.5	P5	14	21.1	28.1	27.3	27.3	71.3	89.8	2780	1660	1660	2794	10530	HRC 45 MN
M6x12.5	P5	14	22	29.5	28.5	29.5	103.4	127.3	3945	2725	2725	4780	14060	HRC 55 MN

M3x5.5	P4	10	6	9.4	13.1	13.8	20.4	31.1	415	390	390	400	2280	HRC 20 ML
M3x6.5	P4	12	12	16.3	21	22	30.7	46.5	735	710	710	685	3020	HRC 25 ML
M6x5	P5	12	10.5	15	21.7	21.8	39.6	56.6	960	950	950	1150	4380	HRC 30 ML
M6x7	P5	12	15	22	25.1	25.8	54.7	78.3	1935	1555	1555	1953	6790	HRC 35 ML
M6x10.5	P5	14	21.1	28.1	35	35	89.5	124.4	3850	3060	3060	4060	10530	HRC 45 ML
M6x12.5	P5	14	22	29.5	42	43	129.9	176.3	5460	5185	5185	6060	14060	HRC 55 ML

M3x6.5	P4	12	8	12.3	16.6	17.6	24.8	34.3	540	385	385	470	3020	ERC 25 MN
M3x6.5	P4	12	8	12.3	21	22	30.7	46.5	960	950	950	610	3020	ERC 25 ML

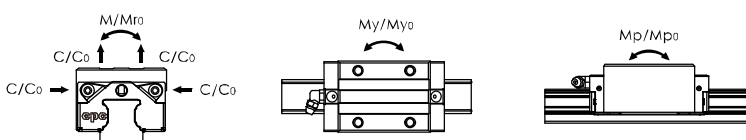

The above rating load capacities and static moment are calculated according to ISO14728 standard. The rating life for basic dynamic load rating is defined as the total 100km travel distance that 90% of a group of identical linear guides can be operated individually under the same conditions free from any material damage caused by rolling fatigue. When the standard of 50km travel distance is applied, the above basic dynamic load rating C of ISO 14728 should be multiplied by 1.26 for conversion.

Dimensions Table

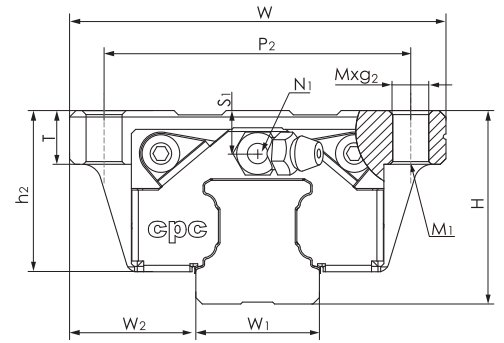
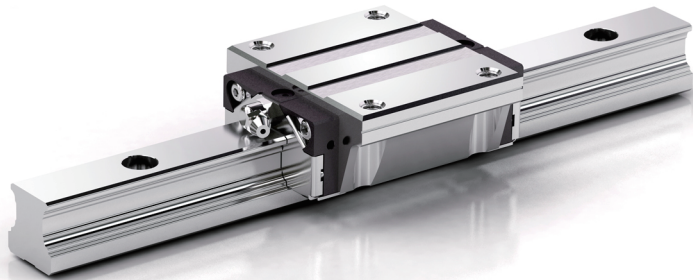

HRC FN Series

Model Code	Mounting Dimensions		Rail Dimensions(mm)				Block Dimensions(mm)									
	H	W ₂	W ₁	H ₁	P	Dx dx g ₁	W	L	L ₁	h ₂	P ₁	P ₂	Mxg ₂	M ₁	T	N ₁
HRC 15 FN	24	16	15	15	60	7.5x4.5x5.3	47	55.5	40.3	20.7	30	38	M5x7	M4	7	M3x6.5
HRC 20 FN	30	21.5	20	20	60	9.5x6x8.5	63	69	52	25	40	53	M6x10	M5	10	M3x7.5
HRC 25 FN	36	23.5	23	23	60	11x7x9	70	81.2	62.2	30	45	57	M8x12	M6	12	M6x7.5
HRC 30 FN	42	31	28	27	80	14x9x12	90	95.5	71.5	35.2	52	72	M10x15	M8	16	M6x8.5
HRC 35 FN	48	33	34	32	80	14x9x12	100	111.2	86.2	40.4	62	82	M10x15	M8	16	M6x10
HRC 45 FN	60	37.5	45	39	105	20x14x17	120	135.5	102.5	50.7	80	100	M12x18	M10	19	PT1/8x12.5
* HRC 55 FN	70	23.5	53	46	120	24x16x18	140	155.6	118.6	58	95	116	M14x20	M12	20	PT1/8x14.5

HRC FL Series

HRC 20 FL	30	21.5	20	20	60	9.5x6x8.5	63	87.2	70.2	25	40	53	M6x10	M5	9	M3x7.5
HRC 25 FL	36	23.5	23	23	60	11x7x9	70	105	86	30	45	57	M8x12	M6	12	M6x7.5
HRC 30 FL	42	31	28	27	80	14x9x12	90	118	94	35.2	52	72	M10x15	M8	16	M6x8.5
HRC 35 FL	48	33	34	32	80	14x9x12	100	136.6	111.6	40.4	62	82	M10x15	M8	16	M6x10
HRC 45 FL	60	37.5	45	39	105	20x14x17	120	171.5	138.5	50.7	80	100	M12x18	M10	19	PT1/8x12.5
* HRC 55 FL	70	23.5	53	46	120	24x16x18	140	202.5	165.5	58	95	116	M14x20	M12	20	PT1/8x14.5

1. The model is in design

3. N₂ = Injecting holes

5. N₂ will be seal before shipment, open it when using product.

2. The load capacities is for-full ball type (No ball chain)

4. N₃ = O-ring seal

LINEAR MOTION TECHNOLOGY

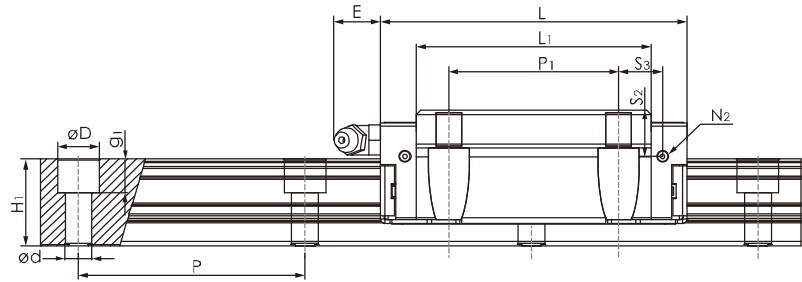
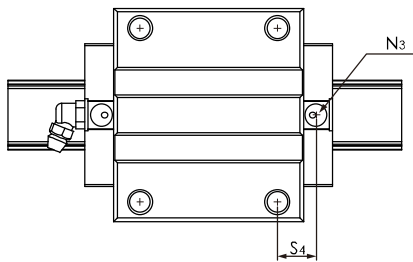

Block Dimensions(mm)							Load Capacities (kN)		Static Moment (Nm)			Weight		Model Code
N2	N3	E	S1	S2	S3	S4	C	C0	Mro	Mp0	My0	Block(g)	Rail(g/m)	
M3x6	P3	3.5	4.5	7.5	7.8	8.9	9.9	14.1	140	105	105	174	1290	HRC 15 FN
M3x5.5	P4	10	6	9.4	9	9.7	17.1	24.2	325	230	230	396	2280	HRC 20 FN
M3x6.5	P4	12	8	12.3	11.6	12.6	24.8	34.3	540	385	385	626	3020	HRC 25 FN
M6x5	P5	12	7.5	12	14.8	14.5	32.8	43.3	705	565	565	1110	4380	HRC 30 FN
M6x7	P5	12	8	15	17.4	18.1	45.9	60.9	1505	955	955	1550	6790	HRC 35 FN
M6x10.5	P5	14	11.1	18.1	17.3	17.3	71.3	89.8	2780	1660	1660	2747	10530	HRC 45 FN
M6x12.5	P5	14	12	19.5	28.5	29.5	103.4	127.3	3945	2725	2725	5260	14060	HRC 55 FN

M3x5.5	P4	10	6	9.4	18.1	18.8	20.4	31.1	415	390	390	504	2280	HRC 20 FL
M3x6.5	P4	12	8	12.3	23.5	24.5	30.7	46.5	735	710	710	605	3020	HRC 25 FL
M6x5	P5	12	7.5	12	25.7	25.8	39.6	56.6	960	950	950	1385	4380	HRC 30 FL
M6x7	P5	12	8	15	30.1	30.8	54.7	78.3	1935	1555	1555	2000	6790	HRC 35 FL
M6x10.5	P5	14	11.1	18.1	35	35	89.5	124.4	3850	3060	3060	4280	10530	HRC 45 FL
M6x12.5	P5	14	12	19.5	42	43	129.9	176.3	5460	5185	5185	7480	14060	HRC 55 FL

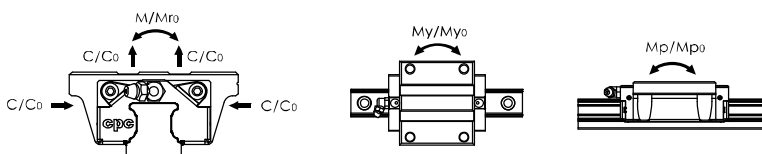

The above rating load capacities and static moment are calculated according to ISO14728 standard. The rating life for basic dynamic load rating is defined as the total 100km travel distance that 90% of a group of identical linear guides can be operated individually under the same conditions free from any material damage caused by rolling fatigue. When the standard of 50km travel distance is applied, the above basic dynamic load rating C of ISO 14728 should be multiplied by 1.26 for conversion.

Dimensions Table

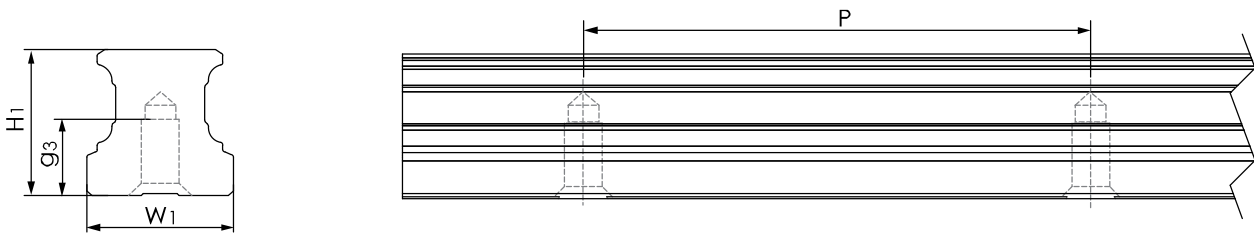

Rail (tapped from the bottom)

Model Code	W1	H1	P	Mxg3	Lmax	Rail(g/m)
ARU 15	15	15	60	M5x7.5	4000	1290
ARU 20	20	20	60	M6x9	4000	2280
ARU 25	23	23	60	M6x12	4000	3020
ARU 30	28	27	60	M8x15	4000	4380
ARU 35	34	32	80	M8x20	4000	6790
ARU 45	45	39	105	M12x20	4000	10530
* ARU 55	53	46	120	M14x22	4000	14060

* The model is in design

Nipple Option

Type			Nipple size		Standard	Option	
			Section	Side			
ARC15	HRC15	-	M3	M3	A-M3	OB-M3-M6	-
ARC20	HRC20	-	M3	M3	B-M3	OB-M3-M6	-
ARC25	HRC25	ERC25	M6	M3	B-M6	OA-M6-M8(PT1/8)	OB-M6-M8(PT1/8)
ARC30	HRC30	-	M6	M6	B-M6	OA-M6-M8(PT1/8)	OB-M6-M8(PT1/8)
ARC35	HRC35	-	M6	M6	B-M6	OA-M6-M8(PT1/8)	OB-M6-M8(PT1/8)
ARC45	HRC45	-	PT1/8	M6	B-PT1/8	OA-PT1/8-M8(PT1/8)	OB-PT1/8-M8(PT1/8)
ARC55	HRC55	-	PT1/8	M6	B-PT1/8	OA-PT1/8-M8(PT1/8)	OB-PT1/8-M8(PT1/8)

A-M3	B-M3	B-M6
B-PT1/8	OB-M3-M6	OA-M6-M8(PT1/8)
OB-M6-M8(PT1/8)	OA-PT1/8-M8(PT1/8)	OB-PT1/8-M8(PT1/8)
<p>M8x1 PT1/8 L=18 W=10 H=24.5 M6x0.75 L=18, W=12 H=24.5</p>	<p>M8x1 PT1/8 C=10, D=11.5 PT 1/8 C=12, D=13.8</p>	<p>M8x1 PT1/8 L=18, W=10, H=20 PT 1/8 L=20, W=12, H=20</p>

* Please note that the specifications are subject to change without notice due to product improvements.

cpc CHIEFTEK PRECISION CO., LTD.

HEADQUARTERS

No.3, Dali 1st Rd., Sinshih Township,
Tainan Science Park, 741-45 Tainan,
Taiwan, R.O.C

TEL:+886-6-505 5858

[Http://www.chieftek.com](http://www.chieftek.com)

E-mail:service@mail.chieftek.com

CHIEFTEK PRECISION USA

3857-2E Schaefer Ave.
Chino, CA 91710
TEL:+1-909-628-9300

cpc Europa GmbH

Industriepark 314,
D-78244 Gottmadingen, Germany
TEL:+49-7731-59130-38

CHIEFTEK MACHINERY KUNSHAN CO., LTD.

No.1188, Hongqiao Rd. Kunshan,
Jiangsu, P.R. China

TEL:+86-512-5525 2831